



Fire Safety

Worldwide
Contacts

www.gsfiresafety.com

Model GS256/ GS258, 5.6 K-factor Horizontal Sidewall Sprinklers Standard and Quick Response

General Description

Horizontal sidewall sprinklers are designed for installation along a wall or the side of a beam and are commonly used instead of pendent or upright sprinklers due to aesthetics or building construction considerations, where piping across the ceiling is not desirable.

Corrosion resistant coatings, where applicable, are utilized to extend the life of copper alloy sprinklers beyond that which would otherwise be obtained when exposed to corrosive atmospheres. Although corrosion resistant coated sprinklers have passed the standard corrosion tests of the applicable approval agencies, the testing is not representative of all possible corrosive atmospheres. Consequently, it is recommended that the end user be consulted with respect to the suitability of these corrosion resistant coatings for any given corrosive environment. The effects of ambient temperature, concentration of chemicals, and gas/chemical velocity, should be considered, as a minimum, along with the corrosive nature of the chemical to which the sprinklers will be exposed

NOTICE

The Model GS256/ GS258 Sprinklers described herein must be installed and maintained in compliance with this document and with the applicable standards of the National Fire Protection Association (NFPA), in addition to the standards of any authorities having jurisdiction. Failure to do so may impair the performance of these devices.

The owner is responsible for maintaining their fire protection system and devices in proper operating condition. The installing contractor or sprinkler manufacturer should be contacted with any questions.



Sprinkler Identification

Frame	Brass
Deflector	Brass
Compression Screw	Brass
Plug	Brass
Bulb (5 mm/ 3mm)	Glass
Sealing Assembly ..	Rubber

Operation

The glass bulb contains a fluid that expands when exposed to heat. When the rated temperature is reached, the fluid expands sufficiently to shatter the glass bulb, allowing the sprinkler to activate and water to flow.



Fire Safety

Components:

- 1- Frame
- 2- Deflector *
- 3- Compression Screw
- 4- Bulb
- 5- Plug
- 6- Sealing Assembly

* Temperature rating is indicated on Deflector.

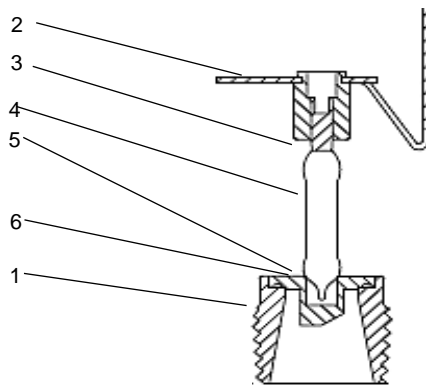
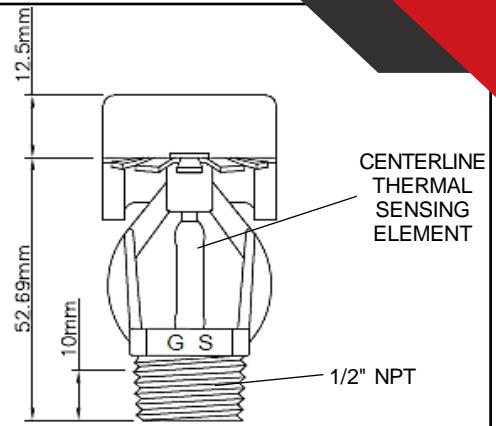

FIGURE 1

MODEL GS256, 5.6 K-FACTOR, HORIZONTAL SIDEWALL SPRINKLER STANDARD RESPONSE



Components:

- 1- Frame
- 2- Deflector *
- 3- Compression Screw
- 4- Bulb
- 5- Plug
- 6- Sealing Assembly

* Temperature rating is indicated on Deflector.

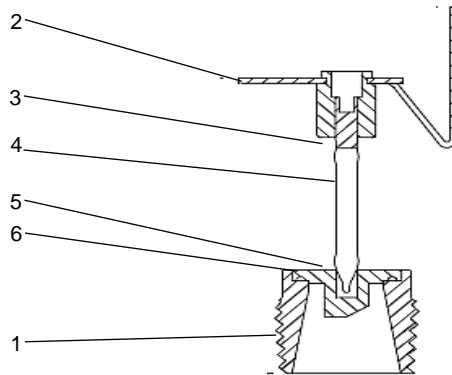

FIGURE 2

MODEL GS258, 5.6 K-FACTOR, HORIZONTAL SIDEWALL SPRINKLER QUICK RESPONSE

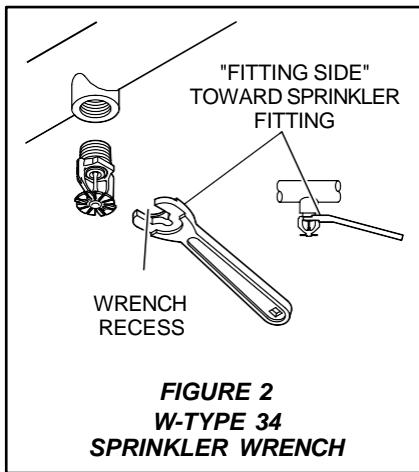
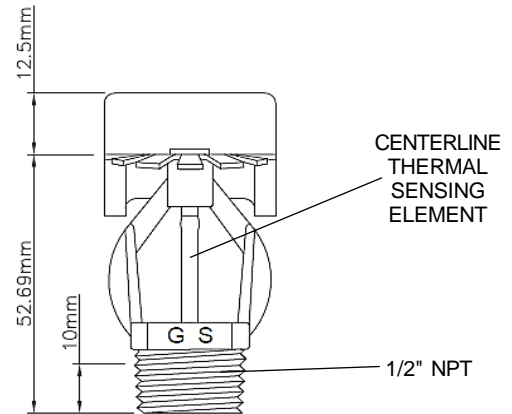

FIGURE 2
W-TYPE 34
SPRINKLER WRENCH

Item	Description
Sprinkler Identification	GS256/ GS258
K-factor, gpm/psi ^{1/2} (Lpm/bar ^{1/2})	5.6 (80 L/min/bar ^{0.5})
Temperature Rating °F (°C)	155°F (68°C) 200°F (93°C) 286°F (141°C)
Thread Size	1/2 in. NPT
Sprinkler Orientation	Upright/ Pendent
Maximum Working Pressure, psi (bar)	175 psi (12 bar)

TECHNICAL DATA

Note:

Installation

- Upright Sprinklers (GS256):** Install with the frame arms parallel to the branch line.
- Pendent Sprinklers (GS258):** Install with the frame arms perpendicular to the ceiling.
- Use the appropriate sprinkler wrenches to prevent damage during installation.
- Maintain proper clearance from obstructions as per local fire codes and regulations.

- Step 1.** With pipe thread sealant applied, hand-tighten the sprinkler into the sprinkler fitting.
- Step 2.** Wrench-tighten the Model GS256/ GS258 Sprinkler using only the W-Type 34 Sprinkler Wrench as shown in Figure 2, and by fully engaging (seating) the wrench on the sprinkler wrench flats
- Step 3.** After installation, inspect the bulb of each Model GS256/ GS258 Sprinkler for damage. In particular, verify that the bulb is not cracked. Replace damaged sprinklers.